

29L dark grey countertop microwave oven, Inverter, 900W power, touch and dial control, and auto-return turntable.



## Product Details

### FEATURES

---

Inverter technology

Quick and easy-to-use dial control

One touch Quick start

Auto-return turntable

---

900 watts power

9 auto menus

10 power levels

---

### BENEFITS

---

**Faster, even cooking with inverter technology**  
Deliver tasty results every time thanks to our inverter technology which provides more even heating. Inverter technology is also more energy efficient and cooks faster than non-inverter microwaves.

**Stylish and functional control panel**  
The new sleek, seamlessly designed microwave fits perfectly into your kitchen, with a touch control panel and an easy-to-use knob, you will have a simple to use and stylish microwave all in one with a control panel that is much more durable and long-lasting.

---

**Heating in a hurry with the press of a button**  
In a rush and need a quick re-heat? The quick start function automatically adds 30 seconds to your time, with just the press of one button, making it easy for the quick heat-ups.

**Safe and easy handling with the auto-return turntable**  
Want a safer and easier way to remove items from the microwave? With position-memory the turntable will reset to its original position once finished, meaning your mug or plate will be in the exact same position as to when you put it in.

---

**Cook with speed**  
Our 900-watt microwave oven, heats your food fast so you'll solve your cravings just as fast as they hit.

**Set and forget**  
Take the guesswork out of microwaving with our pre-defined set of Auto Menus that are designed to cook specific foods, such as popcorn, soup, and pasta. The menus will select the correct power level and cooking time making it easier for you.

---

## Specifications

### PRODUCT PROFILE

---

Domestic warranty details (yrs)	1
---------------------------------	---

---

Type of Microwave	solo
-------------------	------

---

### DIMENSIONS

---

#### PRODUCT

---

Total height (mm)	302
-------------------	-----

---

Total width (mm)	495
------------------	-----

---

Total depth (mm)	380
------------------	-----

---

### CONTROLS

### PROGRAMS

---

#### PROGRAM OPTIONS

---

Number of Programmed functions	9
--------------------------------	---

---

Auto cook programs	Yes
--------------------	-----

---

Auto cook from frozen programs	Yes
--------------------------------	-----

---

Auto weight defrosting programs	Yes
---------------------------------	-----

---

Auto weight programs	No
----------------------	----

---

### INTERNAL

---

Turntable diameter (mm)	288
-------------------------	-----

---

### TIMER

## CONTROLS

---

Controls	touch,electronic rotary dial
----------	------------------------------

---

Display	LED
---------	-----

---

Knob finish	silver
-------------	--------

---

Child safety	Yes
--------------	-----

---

Number of power levels	10
------------------------	----

---

## EXTERIOR

---

Type	free standing (countertop)
------	----------------------------

---

Fascia material/Colour	glass
------------------------	-------

---

Trim	No
------	----

---

Outer wrap colour	charcoal grey
-------------------	---------------

---

## DOOR

---

Door opening mechanism	push button
------------------------	-------------

---

Door opening	side opening
--------------	--------------

---

## SHIPPING

## TIMER

---

Type of timer	programmable timer
---------------	--------------------

---

Signals	end
---------	-----

---

Timer functions	acoustic signal,duration,stop,time of day
-----------------	---

---

## INTERIOR

---

Interior finish	painted steel
-----------------	---------------

---

Interior Options	glass turntable
------------------	-----------------

---

Grill	no grill
-------	----------

---

Capacity (litres)	29
-------------------	----

---

## POWER

---

Power Connection	10 amp plug and cord
------------------	----------------------

---

Microwave power watts	900
-----------------------	-----

---

## SHIPPING

---

Shipping Weight (Kg)	11.4
----------------------	------

---

Pack Dimensions Height (mm)	370
-----------------------------	-----

---

Pack Dimension Width (mm)	562
---------------------------	-----

---

Pack Dimension Depth (mm)	475
---------------------------	-----

---

# Dimensions

**Microwave**  
WMF2905GA

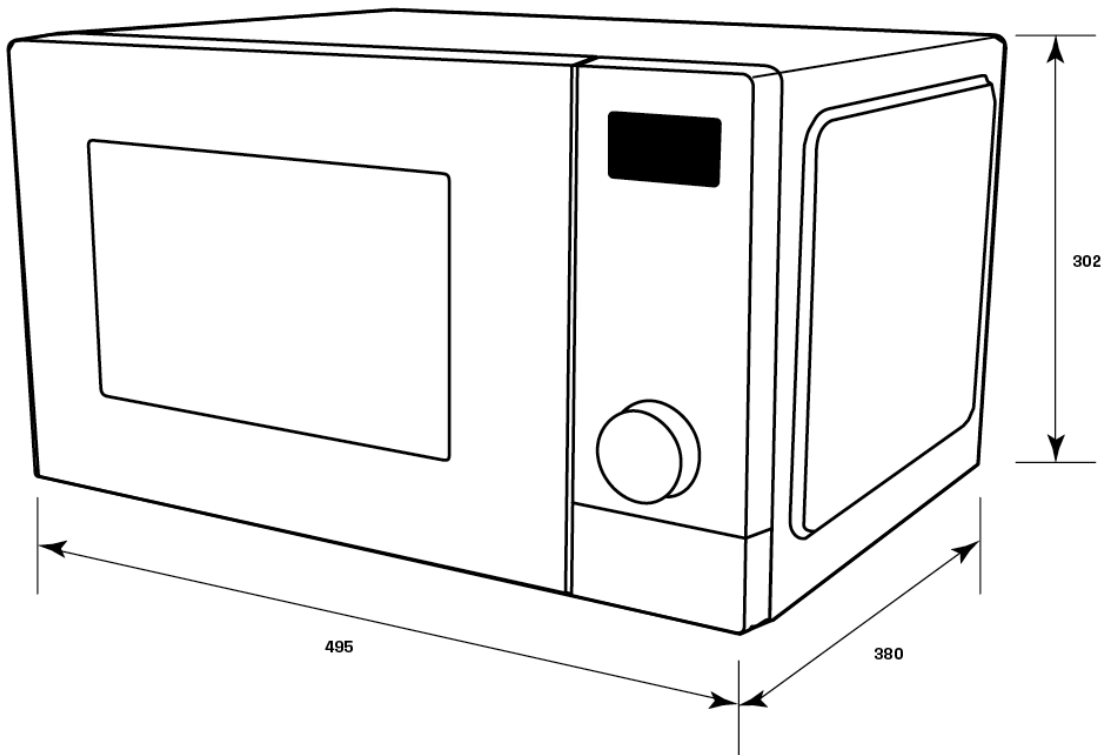

Product WxHxD (mm)

495 x 302 x 380

**IMPORTANT**

These dimensions are a guide only. All measurements are in millimetres (mm).  
For complete installation instructions, refer to the manual provided with product.

© 2023 Electrolux Home Products Pty Ltd. ABN 51 004 762 341. WHS\_DIM\_Aspire\_Plus\_WMf2905GA\_Apr23

# Terms and Conditions

## IMPORTANT

This is a guide of product dimensions only. For complete installation instructions, refer to the manual provided with product.

## PRODUCT INFORMATION

The descriptors and illustrations in this publication apply to the specific products and models described as at the date of issue. Under our policy of continuous product development, product specifications may change without notice. Prospective purchasers should therefore check with their retailer to ensure this publication correctly describes the products that are being offered for sale. All information supplied is to be used for general reference purposes only and is on the understanding that Electrolux Home Products Pty Ltd (Australia) and Electrolux (NZ) Ltd (New Zealand) will not be liable for any loss, liability or damage of whatever kind arising as a result of reliance on such information. Colours of products illustrated are as close as printing limitations allow. Electrolux will at all times comply with its obligations pursuant to law including Trade Practices (Australian Consumer Law) Act and Regulations.

## WARRANTY

This warranty only applies to Appliances purchased and used in Australia or New Zealand and used in normal domestic applications and is in addition to (and does not exclude, restrict, or modify in any way) any non-excludable statutory warranties in Australia or New Zealand. All warranties are subject to the conditions set out in the warranty card accompanying the product when purchased.

### ELECTROLUX HOME PRODUCTS AUSTRALIA

telephone: 1300 363 640

fax: 1800 350 067

email: [customercare@electrolux.com.au](mailto:customercare@electrolux.com.au)

web: [www.electrolux.com.au](http://www.electrolux.com.au)

### ELECTROLUX HOME PRODUCTS NEW ZEALAND

telephone: 09 573 2230

fax: 09 573 2221

email: [customercare@electrolux.co.nz](mailto:customercare@electrolux.co.nz)

web: [www.electrolux.co.nz](http://www.electrolux.co.nz)