

60cm dark stainless steel dual fuel freestanding cooker with multi-function 7 fan forced oven with AirFry, 120 minute timer with ringer, 4 burner gas cooktop with 14.2 mj/hr wok burner and cast iron trivets.



Product Details

FEATURES

AirFry	Electric fan forced oven	Multifunction oven	Easy clean formed shelf supports
2 hour mechanical timer	Triple ring wok burner	High powered 14MJ/h wok burner	Cast iron trivets
Electronic ignition	Safety flame failure feature	Dark Stainless Steel Finish	

BENEFITS

AirFry for that perfect, crunch

When a food craving hits, make healthier and delicious food right in your oven with minimal oil. Deliver all the flavour and none of the guilt. AirFry allows you to make healthier, tasty meals for the entire family right in your oven.

Bring out the flavour with high heat

Whip up tasty stir-fries and more with our high-powered wok burner. You'll get the high heat you need with 14 MJ/h of power at its highest setting.

Family safety first

Our cast iron trivets flat design ensure the base of your pots and pans are fully supported, allowing you to have a safe and stable cooking environment.

Clean your shelf supports with ease

When it comes to cleaning your oven we want it to be fuss free, given the design of our shelf supports you can clean the sides of your oven with ease as there are no racks to be removed.

Set for 2 hours and it will ring

The mechanical timer keeps track of your cooking time for 2 hours with a ringer to let you know you are ready to restart the timer or finish your dish.

Sleek and Stylish

With a fingerprint resistant finish dark stainless steel brings a modern feel to any kitchen. With a practical and premium finish you can take your kitchen in a fresh new direction by incorporating dark stainless steel appliances into your plans.

Built in Australia

Westinghouse, has been the heart of the home for generations and the kitchen appliance brand we have always known and trusted to build reliable products. This oven is built in a local factory in Adelaide.

Specifications

PRODUCT PROFILE

Domestic warranty details (yrs)	2
---------------------------------	---

Oven fuel	electric
-----------	----------

Materials/Colour	Dark stainless steel
------------------	----------------------

Controls of Oven	control knob
------------------	--------------

Cooling fan	No
-------------	----

Plinth colour (kickboard)	Dark stainless steel
---------------------------	----------------------

Anti tilt plate	Yes
-----------------	-----

Front/rear controls	front
---------------------	-------

MAIN OVEN

Gross capacity litres	80
-----------------------	----

Useable capacity litres	74
-------------------------	----

Oven function	fan forced
---------------	------------

Number of functions	7
---------------------	---

DIMENSIONS

PRODUCT DIMENSION

Total height (mm)	970
-------------------	-----

Total width (mm)	596
------------------	-----

Total depth (mm)	630
------------------	-----

ELECTRICAL CONNECTION

Connected load KW	4.4
-------------------	-----

Type of connection	20A plug & lead
--------------------	-----------------

MAIN OVEN

Cleaning	easy clean door
----------	-----------------

Oven liner	pyrolux high temperature enamel
------------	---------------------------------

Timer functions	Ringer
-----------------	--------

Lights	1
--------	---

Light wattage	25
---------------	----

Light position	rear
----------------	------

Layers of glass in door	2
-------------------------	---

Shelf support	easy clean formed shelf supports
---------------	----------------------------------

Number of shelves	2
-------------------	---

Number of shelf positions	5
---------------------------	---

Safety features	flame failure safety device
-----------------	-----------------------------

Closed door grilling	Yes
----------------------	-----

Fold down grill element	Yes
-------------------------	-----

SHIPPING

STUFFING QUANTITIES

40ft

96

SHIPPING

Pack Dimensions Height (mm)	1026
-----------------------------	------

Pack Dimension Width (mm)	636
---------------------------	-----

Pack Dimension Depth (mm)	727
---------------------------	-----

COOKTOP (IF APPLICABLE)

PRODUCT PROFILE

Cook top type	gas
---------------	-----

Materials/Colour	stainless steel
------------------	-----------------

Removable trim (for cleaning)	No
-------------------------------	----

Wok included designed to fit cooktop	No
--------------------------------------	----

Knob finish	silver
-------------	--------

LEFT REAR ZONE

Left rear zone	semi-rapid
----------------	------------

STUFFING QUANTITIES

40ft HC	120
---------	-----

ELEMENTS/BURNERS

Cooking zones	4
---------------	---

FEATURES

Trivets	cast iron
---------	-----------

Ignition type	electronic
---------------	------------

CONTROLS

Position of controls	front
----------------------	-------

GAS SPECIFICATIONS

Maximum gas rating (NG)	60
-------------------------	----

Dimensions

60cm Front Control Freestanding Cooker

WFE614SC, WFE616DSC, WFE646DSC

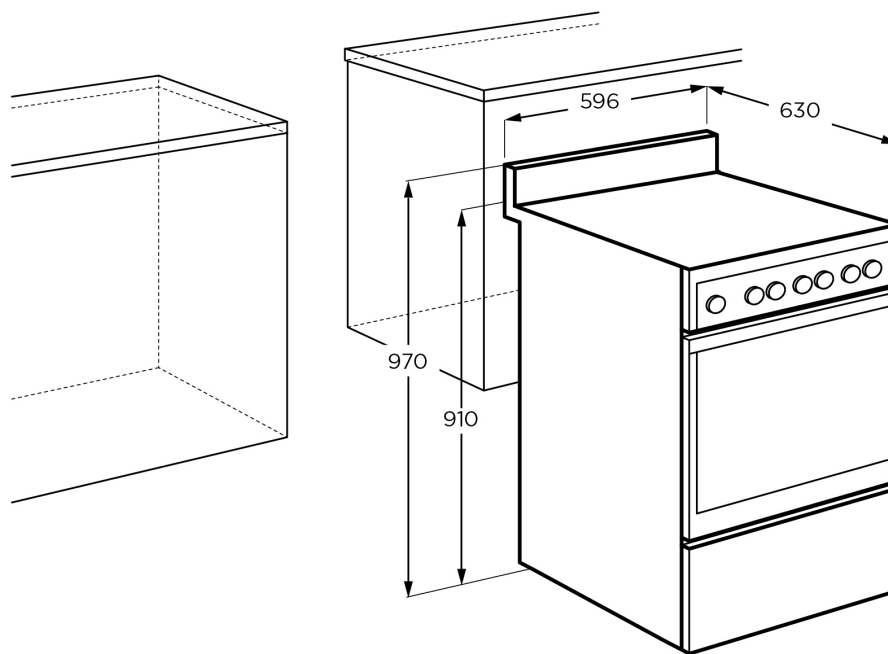

IMPORTANT

These dimensions are a guide only. All measurements are in millimetres (mm).
For complete installation instructions, refer to the manual provided with product.

Terms and Conditions

IMPORTANT

This is a guide of product dimensions only. For complete installation instructions, refer to the manual provided with product.

PRODUCT INFORMATION

The descriptors and illustrations in this publication apply to the specific products and models described as at the date of issue. Under our policy of continuous product development, product specifications may change without notice. Prospective purchasers should therefore check with their retailer to ensure this publication correctly describes the products that are being offered for sale. All information supplied is to be used for general reference purposes only and is on the understanding that Electrolux Home Products Pty Ltd (Australia) and Electrolux (NZ) Ltd (New Zealand) will not be liable for any loss, liability or damage of whatever kind arising as a result of reliance on such information. Colours of products illustrated are as close as printing limitations allow. Electrolux will at all times comply with its obligations pursuant to law including Trade Practices (Australian Consumer Law) Act and Regulations.

WARRANTY

This warranty only applies to Appliances purchased and used in Australia or New Zealand and used in normal domestic applications and is in addition to (and does not exclude, restrict, or modify in any way) any non-excludable statutory warranties in Australia or New Zealand. All warranties are subject to the conditions set out in the warranty card accompanying the product when purchased.

ELECTROLUX HOME PRODUCTS AUSTRALIA

telephone: 1300 363 640

fax: 1800 350 067

email: customercare@electrolux.com.au

web: www.electrolux.com.au

ELECTROLUX HOME PRODUCTS NEW ZEALAND

telephone: 09 573 2230

fax: 09 573 2221

email: customercare@electrolux.co.nz

web: www.electrolux.co.nz