

SPHERE 600DB

LED MIRROR

PRODUCT CODE

S60DB

SPECIFICATIONS

WIDTH	600mm
HEIGHT	600mm
DEPTH	40mm
WEIGHT	9kg

FEATURES

- Copper Free Mirror
- LED Lighting (Adjustable Colour Temperature)
- Backlit
- Touch Sensor
- Demister with 1 Hour Auto Cut-off
- Bluetooth Speakers

LIGHTING SPECIFICATIONS

CCT	2700K - 6500K
CRI	>80

INSTALLATION

- Wall mount
- Hardwire
- Input voltage: 220-240v 50Hz

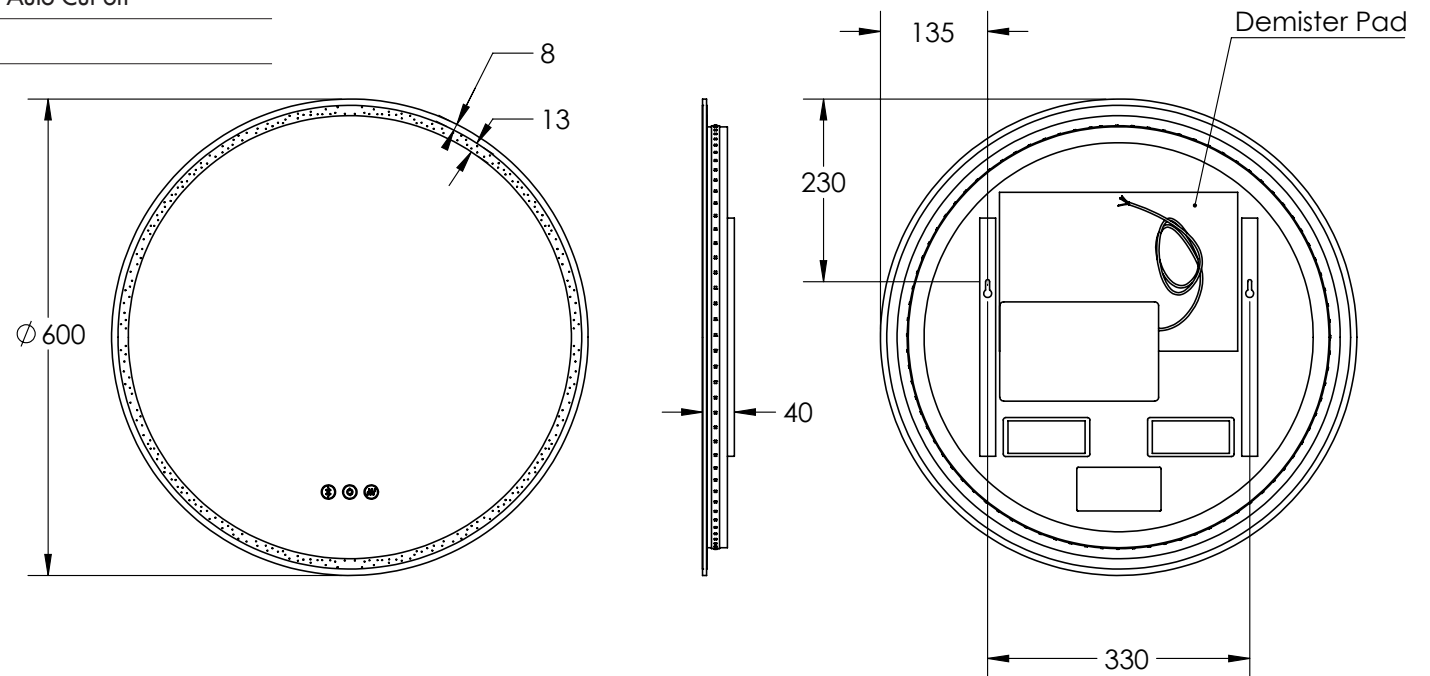

Disclaimer: All LED Products requiring hardwiring must be installed by a licensed electrician in accordance with local regulations. Sizes are in mm and nominal and should be checked prior to installation. Actual colours may vary so please check colour samples before ordering. Installation is acceptance of our products. Installation of faulty, warped, chipped or damaged products will void our warranty.

SPHERE 600DB

LED MIRROR WITH ALUMINIUM FRAME

SPECIFICATIONS

WIDTH	610mm
HEIGHT	610mm
DEPTH	40mm
WEIGHT	10kg

LIGHTING SPECIFICATIONS

CCT	2700K - 6500K
CRI	>80

INSTALLATION

Wall mount
Hardwire
Input voltage: 220-240v 50Hz

FEATURES

- Copper Free Mirror
- LED Lighting (Adjustable Colour Temperature)
- Frontlit
- Touch Sensor
- Demister with 1 Hour Auto Cut-off
- Bluetooth Speakers
- Coloured Aluminium Frame

FINISH		PRODUCT CODE
Brushed Brass		S60DB-BB
Brushed Nickel		S60DB-BN
Gun Metal		S60DB-GM
Matte Black		S60DB-MB
Matte White		S60DB-MW

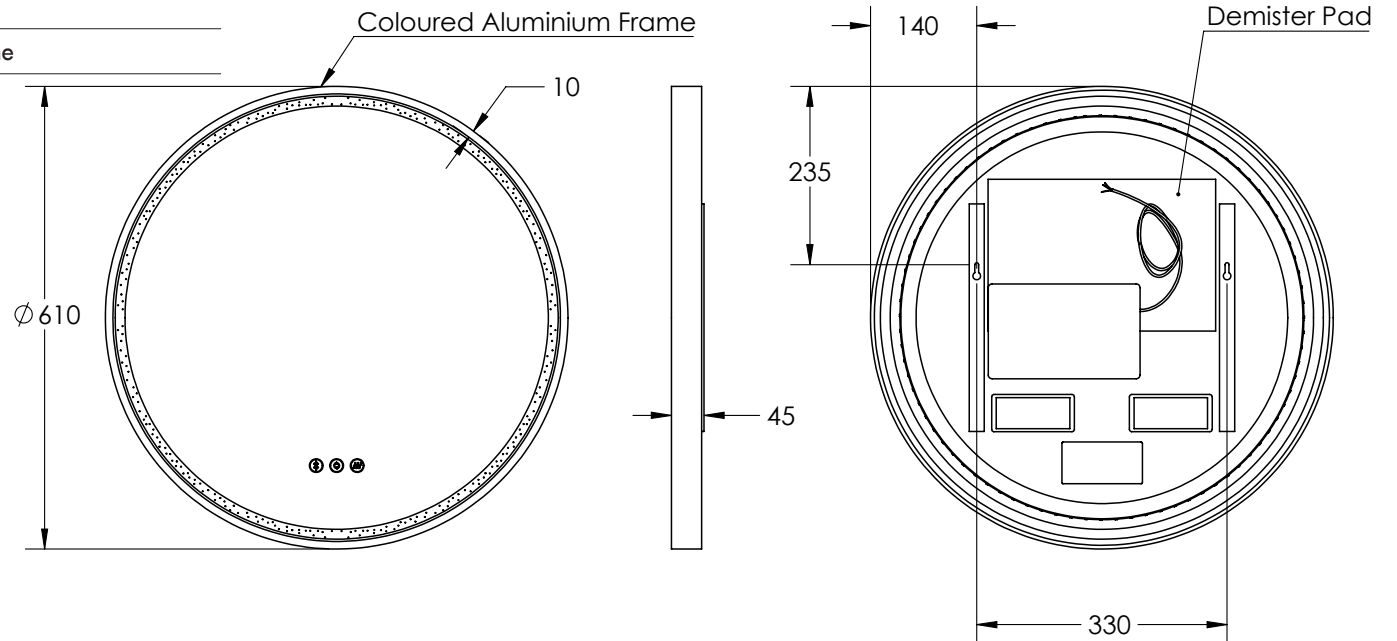

Disclaimer: All LED Products requiring hardwiring must be installed by a licensed electrician in accordance with local regulations. Sizes are in mm and nominal and should be checked prior to installation. Actual colours may vary so please check colour samples before ordering. Installation is acceptance of our products. Installation of faulty, warped, chipped or damaged products will void our warranty.