

Please check actual product in box for bracket type used

GATSBY 450X900D

PRODUCT CODE
G4590D

LED MIRROR

SPECIFICATIONS

WIDTH	450mm
HEIGHT	900mm
DEPTH	31mm
WEIGHT	7kg
ORIENTATION	Portrait/Landscape

FEATURES

Copper Free Mirror
LED Lighting (Adjustable Colour Temperature)
Touch Sensor
Demister with 1 Hour Auto Cut-off

LIGHTING SPECIFICATIONS

CCT	2700K - 6500K
CRI	>80

INSTALLATION

Wall Mount
Hardwire
Input Voltage: 220-240v 50Hz

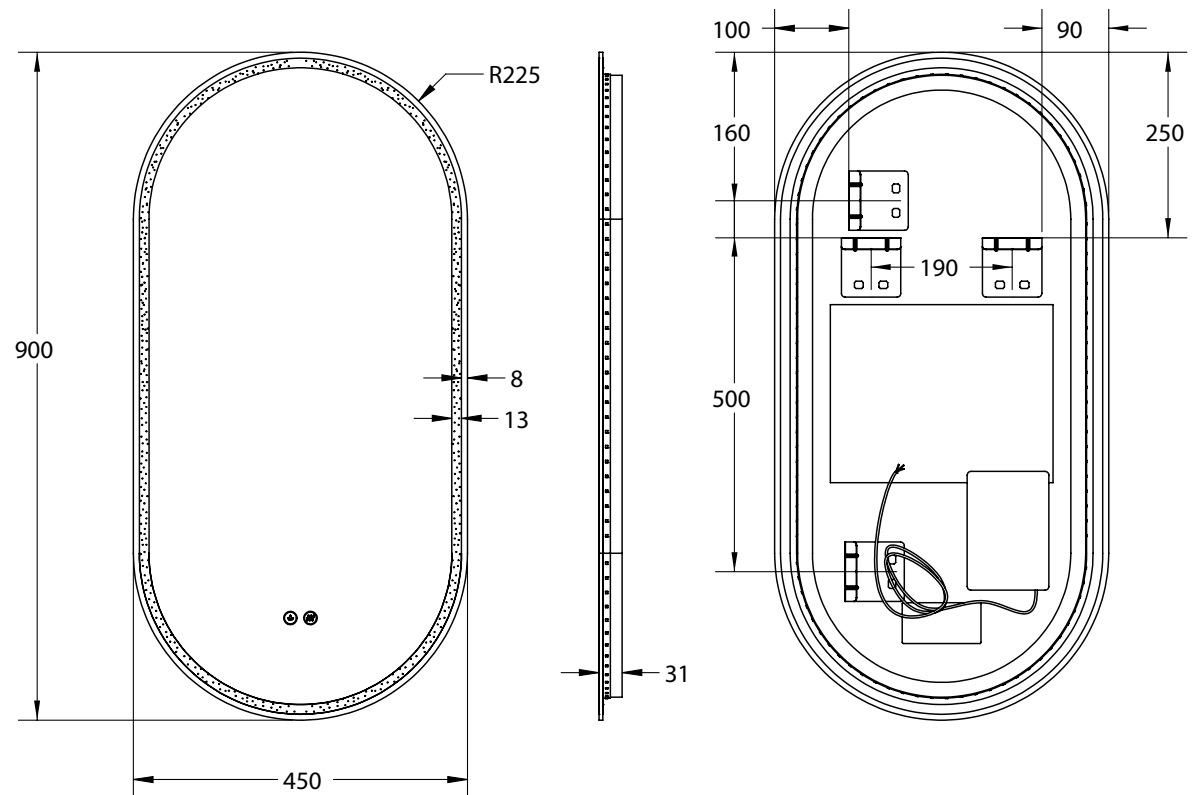

Disclaimer: All LED Products requiring hardwiring must be installed by a licensed electrician in accordance with local regulations. Sizes are in mm and nominal and should be checked prior to installation. Actual colours may vary so please check colour samples before ordering. Installation is acceptance of our products. Installation of faulty, warped, chipped or damaged products will void our warranty.

Please check actual product in box for bracket type used

GATSBY 450X900D

PRODUCT CODE
G4590D

LED MIRROR

SPECIFICATIONS	
WIDTH	450mm
HEIGHT	900mm
DEPTH	35mm
WEIGHT	7kg
ORIENTATION	Portrait/Landscape

FEATURES	
Copper Free Mirror	
LED Lighting (Adjustable Colour Temperature)	
Touch Sensor	
Demister with 1 Hour Auto Cut-off	

LIGHTING SPECIFICATIONS	
CCT	2700K - 6500K
CRI	>80

INSTALLATION	
Wall Mount	
Hardwire / Plug	
Input Voltage: 220-240v 50Hz	

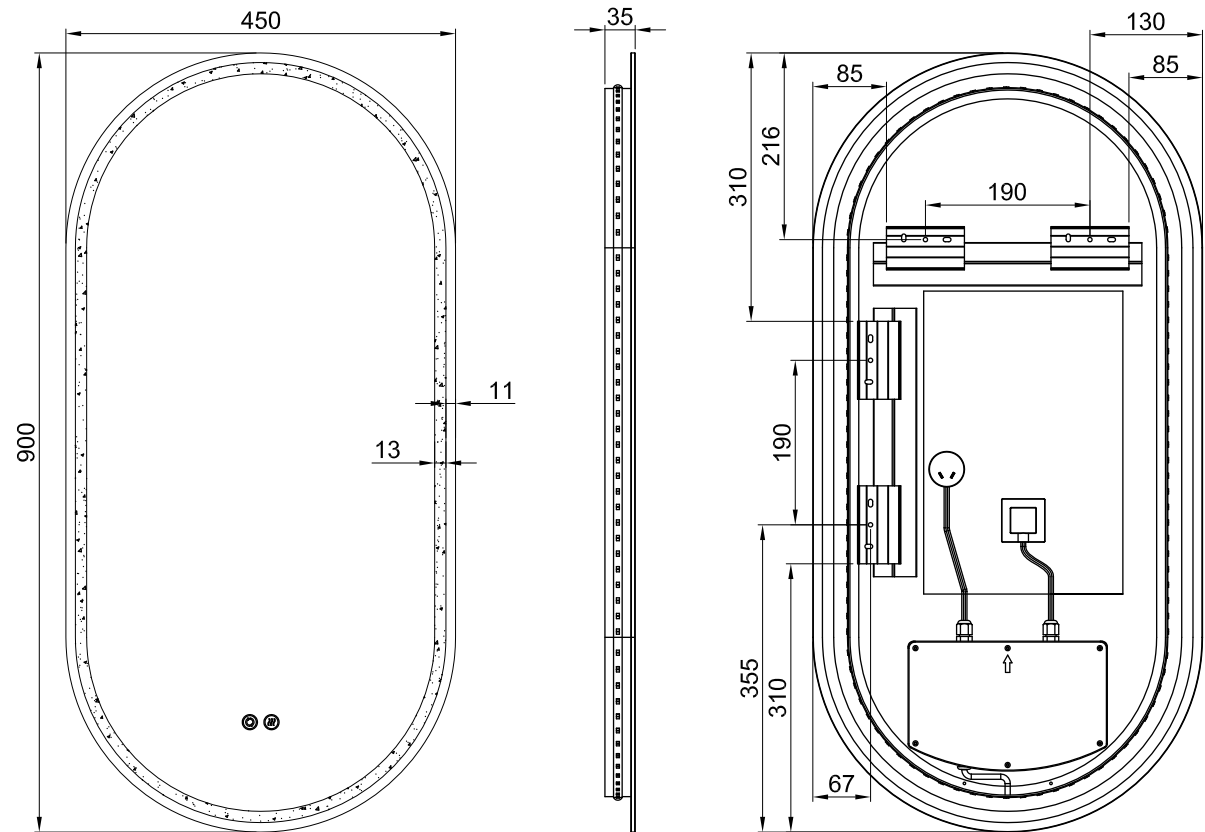

Disclaimer: All LED Products requiring hardwiring must be installed by a licensed electrician in accordance with local regulations. Sizes are in mm and nominal and should be checked prior to installation. Actual colours may vary so please check colour samples before ordering. Installation is acceptance of our products. Installation of faulty, warped, chipped or damaged products will void our warranty.

Please check actual product in box for bracket type used

GATSBY 450X900D

LED MIRROR

SPECIFICATIONS

WIDTH	460mm
HEIGHT	910mm
DEPTH	31mm
WEIGHT	7kg
ORIENTATION	Portrait/Landscape

LIGHTING SPECIFICATIONS

CCT	2700K - 6500K
CRI	>80

INSTALLATION

Wall Mount
Hardwire
Input Voltage: 220-240v 50Hz

FEATURES

Copper Free Mirror
LED Lighting (Adjustable Colour Temperature)
Touch Sensor
Demister with 1 Hour Auto Cut-off

FINISH	PRODUCT CODE
Baltic Brass	G4590D-BB
Brits Nickel	G4590D-BN
Cuban Bronze	G4590D-CB
Georgian Metal	G4590D-GM

FINISH	PRODUCT CODE
Manhattan Black	G4590D-MB
Milano White	G4590D-MW
Nordic Gold	G4590D-NG

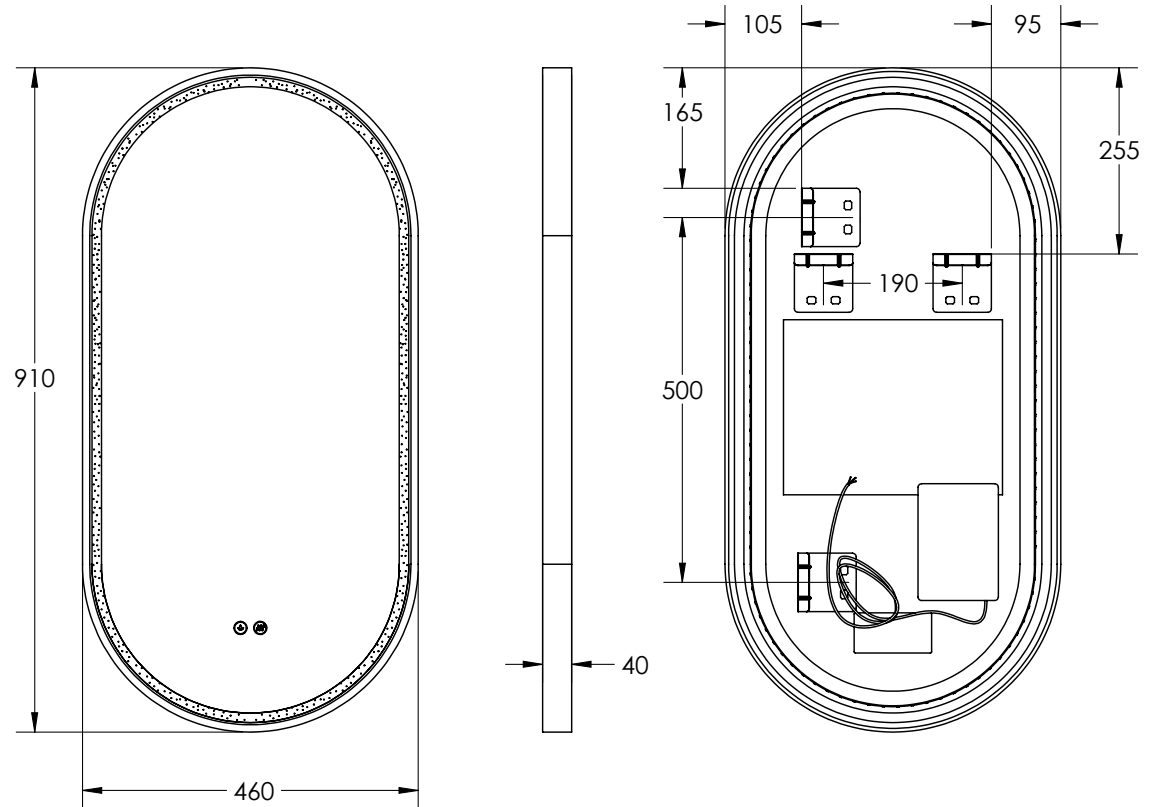

Disclaimer: All LED Products requiring hardwiring must be installed by a licensed electrician in accordance with local regulations. Sizes are in mm and nominal and should be checked prior to installation. Actual colours may vary so please check colour samples before ordering. Installation is acceptance of our products. Installation of faulty, warped, chipped or damaged products will void our warranty.

Please check actual product in box for bracket type used

GATSBY 450X900D

LED MIRROR

SPECIFICATIONS

WIDTH	455mm
HEIGHT	905mm
DEPTH	40mm
WEIGHT	7kg
ORIENTATION	Portrait/Landscape

LIGHTING SPECIFICATIONS

CCT	2700K - 6500K
CRI	>80

INSTALLATION

Wall Mount
Hardwire / Plug
Input Voltage: 220-240v 50Hz

FEATURES

Copper Free Mirror
LED Lighting (Adjustable Colour Temperature)
Touch Sensor
Demister with 1 Hour Auto Cut-off

FINISH	PRODUCT CODE
Baltic Brass	G4590D-BB
Brits Nickel	G4590D-BN
Cuban Bronze	G4590D-CB
Georgian Metal	G4590D-GM

FINISH	PRODUCT CODE
Manhattan Black	G4590D-MB
Milano White	G4590D-MW
Nordic Gold	G4590D-NG

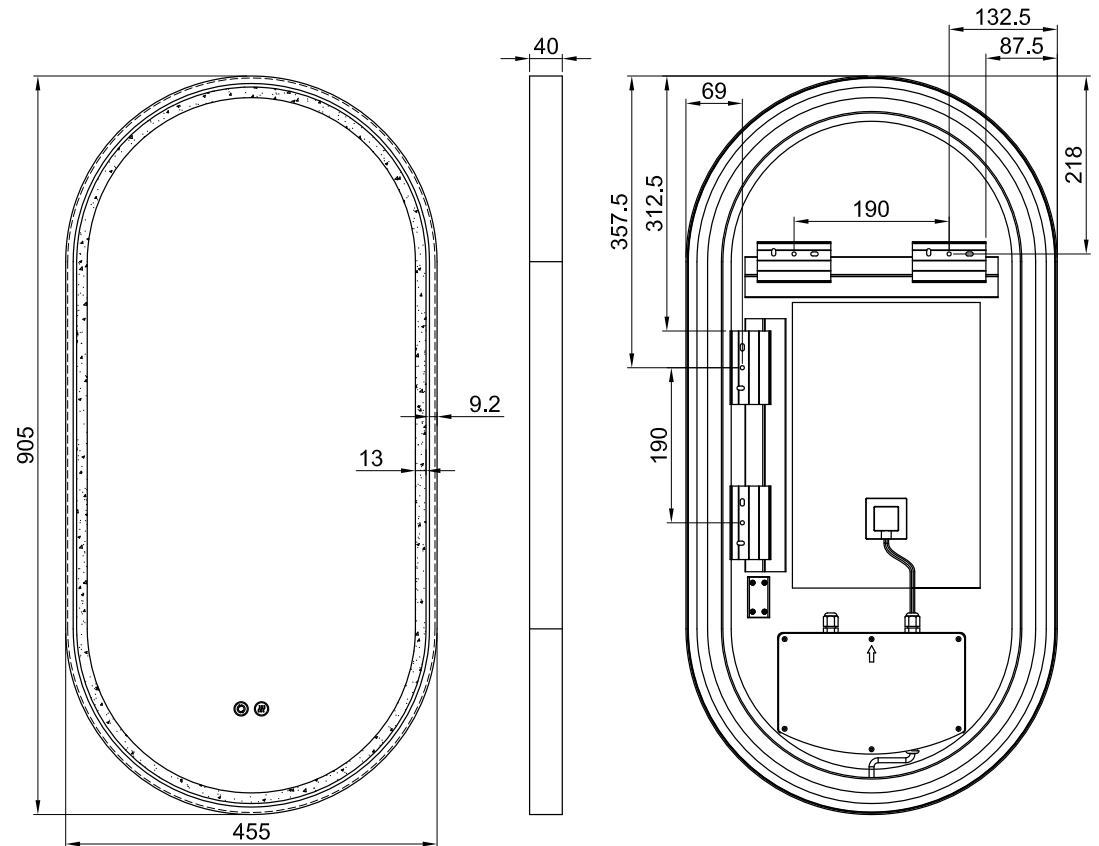

Disclaimer: All LED Products requiring hardwiring must be installed by a licensed electrician in accordance with local regulations. Sizes are in mm and nominal and should be checked prior to installation. Actual colours may vary so please check colour samples before ordering. Installation is acceptance of our products. Installation of faulty, warped, chipped or damaged products will void our warranty.