



**Revision:** 1

**Date:** December 2020

Supersedes all previous issues

# cube

## Invisi II Urinal Suite

Vitreous China Wall-Hung Urinal with Invisi II Cistern for Inwall, Induct or Inceiling applications



# Cube Invisi II Urinal Suite

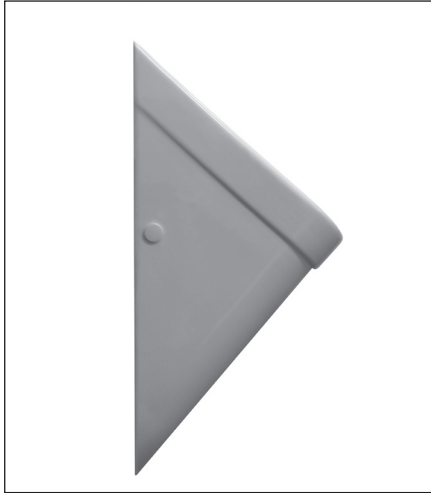

A contemporary design fully integrated box rim, wall mounted urinal with a concealed trap and easy to clean surfaces for low cost maintenance. The box rim flush provides for the wash down of the entire inside area of the bowl on each flush. The grate is vitreous china and factory fitted. Concealed cistern and plumbing fittings provide space saving, ease of cleaning and performance matched components to maximise flushing efficiency.

**Cube Invisi II** urinal suite inwall/induct/inceiling Code No.771600W for AU and 771601W for NZ.

- Traps:** P-trap only.
- Inlet:** Back inlet for concealed nominal 20mm dia. sparge pipe and compression rubber fitting.
- Outlet:** The urinal trap is connected to wall waste pipe which allows for a simple push on urinal connection.
- Cistern:** **Invisi II cistern** – suitable for inwall, induct and inceiling applications. Achieves a 3 star water efficiency rating when installed as a single stall urinal. Buttons are supplied separately, see page 6.15.1 for button and panel options. For inwall applications a blank access panel and remote single flush button are required (not supplied). For induct or inceiling applications where access is available to the cistern and button either the remote or custom buttons are suitable (not supplied).
- Fixing:** The **Cube** urinal is fixed to the wall with the D.167 Concealed Fixing Bracket supplied. **Cistern** is simply mounted into position by clipping onto the two quick clip mounting brackets which are secured with screws to the studwork or induct brickwork. Cistern brackets supplied.
- Colours:** White only.
- Dimensions:** All dimensions are in millimetres and are subject to normal manufacturing variations. Caroma pursues a policy of continuing improvement in design and performance of its products. The right is therefore reserved to vary specifications without notice.

## Cube Invisi II Urinal Inwall/Induct Installation

### Inwall Urinal Suite

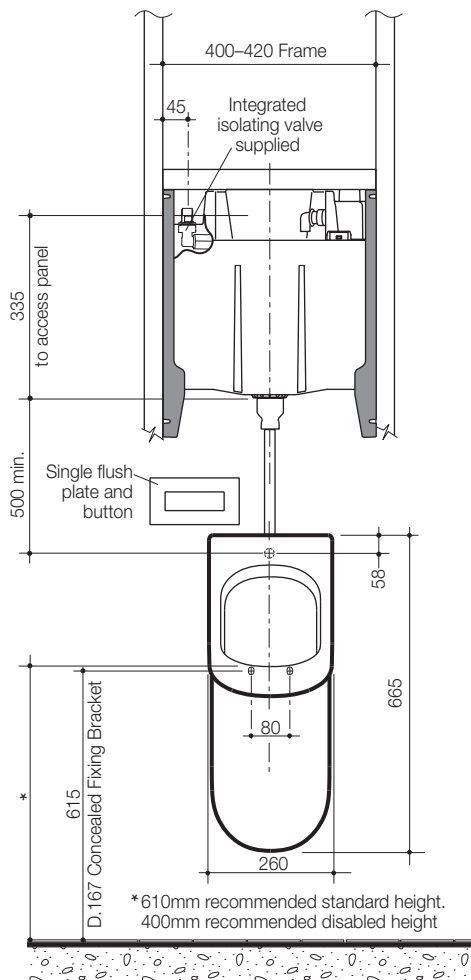

### Induct Urinal Suite

