



# OCS8487B

Installation type: Built-in  
 Range: Craft  
 Available colour: Black steel  
 Product dimensions (HxWxD): 45,5 x 59,7 x 54,7 cm  
 5 Air Flow System, Pure steam system, Oven volume 50l, Aqua Clean, 1 level telescopic fully extendable, SousVide, Auto Roast, Defrost, Eco



**5 Air Flow System**



**Pure steam system**



**50 LITRE Oven volume 50l**



**Aqua Clean**



**1 level telescopic fully extendable**



**SousVide**



**Auto Roast**



**Defrost**



**ECO Eco**



## Construction & Performance

- Maximum oven temperature: 230 °C
- Meat probe
- Multi Steam 360

## Use & Flexibility

- Oven lighting: Both sides
- Water container: 1,3 l
- Oven useful volume (old energy label): 50 l
- OpenView
- Fully extendable guides
- Fully extendable telescopic guides on one level with stop function
- Grid
- Steam tray
- 1 full width perforated steam tray
- 1 Shallow tray

## Interaction & Control

- Knob shape: Ergonomical dials
- TFT display

## Standard accessories

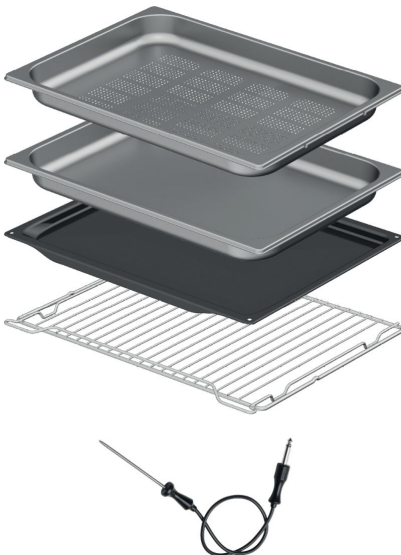

## Programs, options and modes

- Lower heater BIO
- Upper Heater
- Lower and upper heater
- Small infra heater
- Large Infra Heater
- Large infra heater with ventilation
- Circular heater
- Eco-function
- Lower heater and fan
- Lower heater with fan BIO
- Strong steam
- Medium steam
- Low steam
- Steam baking
- SousVide
- Defrost cooker
- WarmPlate
- StayWarm function
- Fast Preheat
- STEPBake
- Auto roast function

## Design & Integration

- Door material: Glass
- Available colour: Black steel
- Touch Free Inox
- Adjustable feet: 4
- Niche dimensions (HxWxD): 45 x 56 x 55 cm

**Safety & Maintenance**

- Dynamic oven cooling plus - DC+
  - Soft open and gentle close door hinge
  - Removable flat oven inner door glass surface
  - AquaClean function
  - SousVide
  - Descaling
- 

**Technical data**

- Consumption in standby mode: 1 W
  - Energy class: A+
  - Oven consumption (conventional operation): 0,82 kWh
  - Oven consumption (venting operation): 0,62 kWh
  - Energy consumption conventional oven (old energy label): 0,82 kWh
  - Energy consumption forced air assisted oven (old energy label): 0,62 kWh
  - Connection rating: 2900 W
  - Nominal current: 16 amp
  - Frequency: 50 Hz
- 

**Dimensions**

- Product dimensions (HxWxD): 45,5 x 59,7 x 54,7 cm
  - Length electrical cord: 1,5 m
  - Net weight: 43,5 kg
- 

**Logistic information**

- Dimensions of packed product (HxWxD): 55 x 66 x 70 cm
  - Gross weight: 48,2 kg
  - Product code: 736309
  - EAN code: 3838782424663
  - Range: Craft
-

