

**90cm TouchSure 5 burner gas on ceramic glass cooktop with electronic touch control, multi-ring triple crown wok burner with dual valve control and Hob2Hood. Available only in Natural Gas configuration.**



## Product Details

### FEATURES

---

Electronic touch controls	Hob2Hood Hob2Hood automatically adjusts your hood settings so you can focus on creating delicious dishes.	Pause Function The pause function sets zones to the lowest setting to keep dishes warm and prevent overcooking.	Flame failure safety device
Residual heat indicators	Child safety device lock	Cast iron pan supports	

---

### BENEFITS

---

Electronic Touch Controls Full control of the flame. The cooktops electronic touch controls react quickly and accurately to your every touch.	Hob2Hood Leave Hob2Hood to regulate the fan while you concentrate on the key moments involved in getting your dish just right. It will automatically control your rangehood's fan and lights.
Pause Function With the Pause Function function, one touch pauses the cooking process, whilst another restarts it again with the same settings.	Flame Failure Safety Device If the flame of your gas burner is accidentally extinguished, the flame failure device will switch off the gas supply to ensure the utmost safety.

---

## Specifications

### PRODUCT PROFILE

Domestic warranty details (yrs)	5
Cooktop type	gas
Materials/Colour	black ceramic glass

### DIMENSIONS

Total product height (mm)	104
Total product width (mm)	890
Total product depth (mm)	510
Cut out width (mm)	850
Cut out depth (mm)	490
Cut out height (mm)	52

### CONTROLS

Controls of Cooktops	Touch and Slide controls
Position of controls	front
Functions of Cooktops	Hob2Hood,stop and go,timer,acoustic signal
Features of Cooktop	minute minder,safety child lock,Hob2Hood Connectivity,hot surface indicator
Timer of Cooktop	CountUp

### FEATURES

Trivets	cast iron
---------	-----------

## ELEMENTS/BURNERS

---

### LEFT FRONT ZONE

---

Left front zone	semi-rapid
-----------------	------------

---

### CENTRE FRONT ZONE

---

Centre front zone	triple ring wok
-------------------	-----------------

---

### RIGHT REAR ZONE

---

Right rear zone	semi-rapid
-----------------	------------

---

## GAS SPECIFICATIONS

---

Maximum gas rating (NG)	37.8
-------------------------	------

---

### LEFT REAR ZONE

---

Left rear zone	semi-rapid
----------------	------------

---

### RIGHT FRONT ZONE

---

Right front zone	simmer
------------------	--------

---

## ELECTRICAL SPECIFICATIONS

---

Connected load KW	3.7
-------------------	-----

---

Maximum current rating (amps)	10
-------------------------------	----

---

Type of connection	10A plug & lead
--------------------	-----------------

---

## SHIPPING

---

Shipping Weight (Kg)	21.2
----------------------	------

---

Pack Dimensions Height (mm)	160
-----------------------------	-----

---

Pack Dimension Width (mm)	875
---------------------------	-----

---

## SHIPPING

---

Pack Dimension Depth (mm)	626
------------------------------	-----

---

## STUFFING QUANTITIES

---

20ft	252
------	-----

---

40ft	504
------	-----

---

## Dimensions

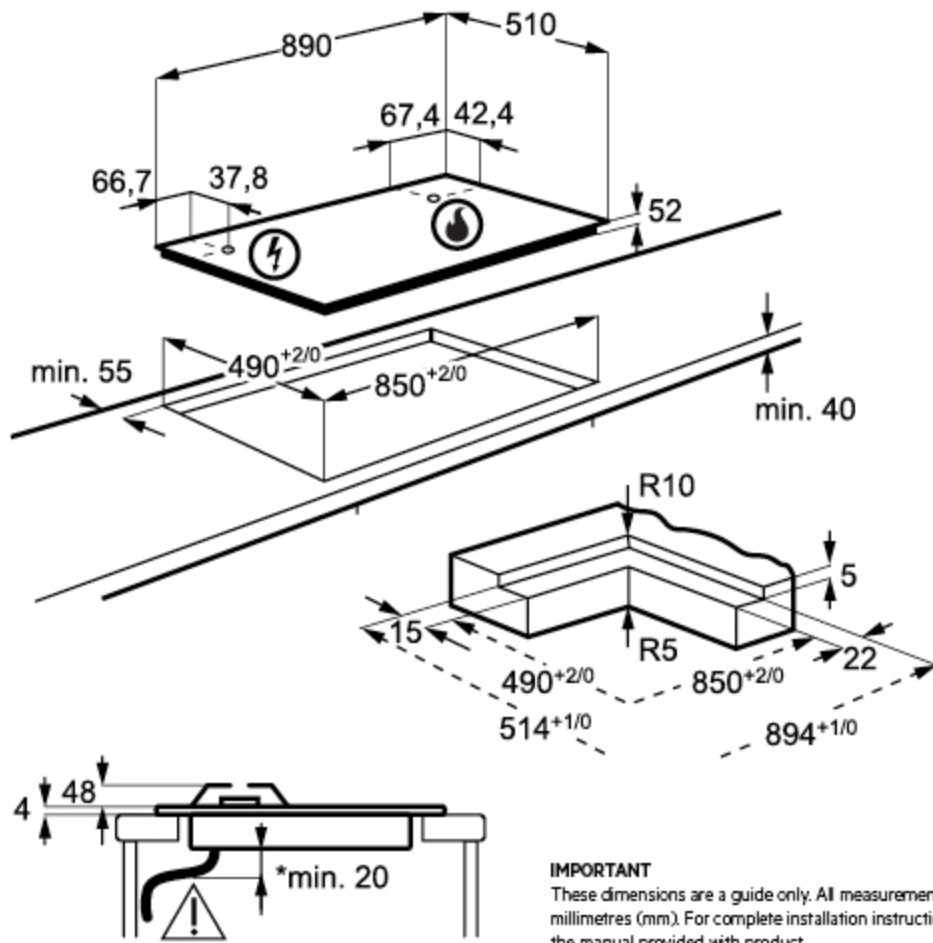

**IMPORTANT**  
 These dimensions are a guide only. All measurements are in millimetres (mm). For complete installation instructions, refer to the manual provided with product.

## Terms and Conditions

### IMPORTANT

This is a guide of product dimensions only. For complete installation instructions, refer to the manual provided with product.

### PRODUCT INFORMATION

The descriptors and illustrations in this publication apply to the specific products and models described as at the date of issue. Under our policy of continuous product development, product specifications may change without notice. Prospective purchasers should therefore check with their retailer to ensure this publication correctly describes the products that are being offered for sale. All information supplied is to be used for general reference purposes only and is on the understanding that Electrolux Home Products Pty Ltd (Australia) and Electrolux (NZ) Ltd (New Zealand) will not be liable for any loss, liability or damage of whatever kind arising as a result of reliance on such information. Colours of products illustrated are as close as printing limitations allow. Electrolux will at all times comply with its obligations pursuant to law including Trade Practices (Australian Consumer Law) Act and Regulations.

### WARRANTY

Electrolux Home Products warrants that for domestic applications the AEG appliances featured are free from defects in materials and workmanship for 5 years (3 months warranty for commercial applications). All warranties are subject to the conditions set out in the warranty card accompanying the product when purchased.

#### ELECTROLUX HOME PRODUCTS AUSTRALIA

telephone: 1300 363 664

fax: 1800 350 067

email: [customercare@aegaustralia.com.au](mailto:customercare@aegaustralia.com.au)

web: [www.aeg.com/au](http://www.aeg.com/au)

#### ELECTROLUX HOME PRODUCTS NEW ZEALAND

telephone: 0800 10 66 10

fax: 09 573 2221

email: [customercare@electrolux.co.nz](mailto:customercare@electrolux.co.nz)

web: [www.aeg.com/au](http://www.aeg.com/au)